

IOM manual

tapflo®

# CTM Magnetic Drive Centrifugal Pumps

edition 2015 rev 1



Read this instruction manual carefully,  
before you install and operate the pump



## Pump models:

CTM20-7  
CTM25-8  
CTM25-10  
CTM32-12.5



» All about your flow

[www.tapflo.com](http://www.tapflo.com)

# CONTENTS

---

0.	GENERAL .....	4
0.1.	Introduction .....	4
0.2.	Warning symbols .....	4
0.3.	Qualification and training of personnel .....	4
0.4.	Pump identification .....	5
1.	INSTALLATION .....	6
1.1.	Operation principle .....	6
1.2.	Receiving inspection .....	6
1.3.	Storage .....	6
1.4.	Foundation .....	7
1.5.	Environment .....	7
1.6.	Suction and discharge piping .....	7
1.6.1.	Connection of discharge pipe .....	7
1.6.2.	Connection of suction pipe .....	7
1.7.	Health and safety .....	8
1.7.1.	Protection .....	8
1.7.2.	Electrical safety .....	8
1.7.3.	Chemical hazard .....	8
1.7.4.	Dry running .....	8
1.7.5.	Noise level .....	8
1.7.6.	Temperature hazards .....	8
1.7.7.	Rotating parts .....	8
1.7.8.	Powerful magnetic field .....	8
1.8.	Example of installation .....	9
1.9.	Solids .....	9
1.10.	Instruments .....	10
1.10.1.	Electric power .....	10
1.10.2.	Optional instruments .....	10
1.10.3.	Thermometer .....	10
1.11.	Motor connection .....	10
2.	OPERATION .....	11
2.1.	Start-up .....	11
2.1.1.	Starting the pump .....	11
2.1.2.	Restarting after power shut-off .....	11
2.2.	Stopping the pump .....	11
3.	MAINTENANCE .....	12
3.1.	Inspections .....	12
3.2.	Location of faults .....	12
3.3.	Disassembly of the pump .....	13

# CONTENTS

---

3.3.1.	Disassembly procedure .....	13
3.4.	Assembly of the pump .....	16
3.4.1.	Test run.....	16
4.	SPARE PARTS .....	17
4.1.	Spare parts drawing .....	17
4.2.	Spare parts list.....	17
4.3.	Recommended spare parts .....	18
4.4.	How to order parts .....	18
5.	DATA.....	19
5.1.	Pump code .....	19
5.2.	Dimensions .....	20
5.3.	Materials, data and limits .....	21
5.4.	Mounting torques and dimensions of screws/nuts .....	21
5.5.	Performance curves .....	22
5.6.	Permitted loads on inlet and outlet.....	23
6.	WARRANTY.....	24
6.1.	Returning parts .....	24
6.2.	Warranty .....	24
6.3.	Warranty form .....	26

# EC DECLARATION



## EC declaration of conformity

Tapflo AB hereby declares with full liability that all centrifugal pumps identified as:

**CTH...; CTI...; CTM...; CTV...; CTS...**

to which the following declaration relates to, comply with the requirements of the following guidelines and harmonized standards:

EN 809:1998+A1:2009  
EN 809:1998+A1:2009/AC:2010  
EN 12162:2001+A1:2009  
EN ISO 20361:2009  
EN 60034-1:2011  
EN 60034-30:2009

and comply with the essential requirements of:

Directive 2006/42/EC of the European Parliament and of the Council of 17 May 2006 on machinery, and amending Directive 95/16/EC;

Directive 2006/95/EC of the European Parliament and of the Council of 12 December 2006 on the harmonization of the laws of Member States relating to electrical equipment designed for use within certain voltage limits;

Directive 2005/32/EC of the European Parliament and of the Council of 6 July 2005 establishing a framework for the setting of eco-design requirements for energy-using products and amending Council Directive 92/42/EEC and Directives 96/57/EC and 2000/55/EC of the European Parliament and of the Council.

The centrifugal pump, to which the following declaration relates to, can be put into operation only if they have been installed according to the manufacturers recommendations and if the installation to which they have been connected to complies with the requirements of the 2006/42/EC directive.

Manufacture by Tapflo Spzoo, Poland for:

Tapflo AB  
Filaregatan 4  
4434 Kungälv, Sweden

Year of CE marking:  
CTV – CE08  
CTM – CE09  
CTI/CTH – CE10  
CTS – CE14

Tapflo AB, June 2<sup>nd</sup>, 2014

Håkan Ekstrand  
Managing director

# 0. GENERAL

---

## 0. GENERAL

### 0.1. Introduction

CTM is a compact and reliable magnetically driven centrifugal pump made in PP and PVDF. With proper attention to maintenance, CTM pumps will give efficient and trouble free operation. This instruction manual will familiarise operators with detailed information about installing, operating and maintaining the pump.

### 0.2. Warning symbols

The following warning symbols are present in this instruction manual. This is what they say:



This symbol stands next to all safety instructions in this instruction manual where danger to life and limb may occur. Observe these instructions and proceed with utmost caution in these situations. Inform also other users of all safety instructions. In addition to the instructions in this instruction manual, the general safety and accident prevention regulations must be observed.



This signal stands at points in this instruction manual of particular importance for compliance with regulations and directives, for correct work flow and for the prevention of damage to and destruction of the complete pump or its subassemblies.



This symbol indicates possible danger caused by strong magnetic field in the vicinity of the pump.



This symbol signals possible danger caused by the presence of electric fields or live wires.

### 0.3. Qualification and training of personnel



The personnel in charge of installation, operation and maintenance of the pumps we produce must be qualified to carry out the operations described in this manual. Tapflo shall not be held responsible for the training level of personnel and for the fact that they are not fully aware of the contents of this manual.

# 0. GENERAL

---

## 0.4. Pump identification

1 – In this field you will find the pump model;

2 – The serial number consist of two 4-digit numbers. The first part is the year and month of manufacturing and the second part is the consecutive number of the pump manufactured in the particular month.

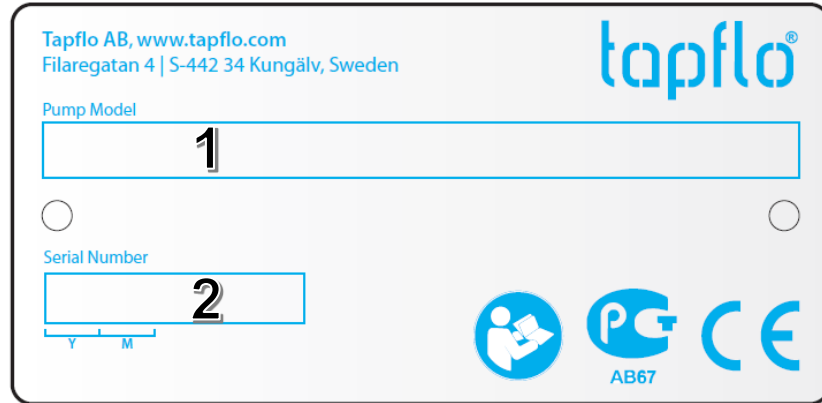



Tapflo AB, [www.tapflo.com](http://www.tapflo.com)  
Filaregatan 4 | S-442 34 Kungälv, Sweden

tapflo®

Pump Model

Serial Number

Y M

    
AB67

# 1. INSTALLATION

## 1. INSTALLATION

### 1.1. Operation principle

In the CTM pump the torque from the motor shaft is transmitted to the impeller by means of a magnetic coupling. The drive magnet (1) is fixed on the motor shaft. The magnets installed in the drive magnet and in the impeller/magnet assembly (2) have different polarity. When the pump is at rest, the magnets of both parts are aligned. When the motor is started and the drive magnet starts to rotate, the magnets create an attraction and repulsion force thus forcing the impeller to rotate. If the impeller gets blocked or the pumped liquid will be too dense and too much torque will be generated on the motor shaft, the magnet will de-couple and no damaged will be done to the motor. When the pump will come to a stop, the magnets will re-couple. Between both magnet assemblies there is located an isolation shell (3) that separates the liquid side from the motor side.

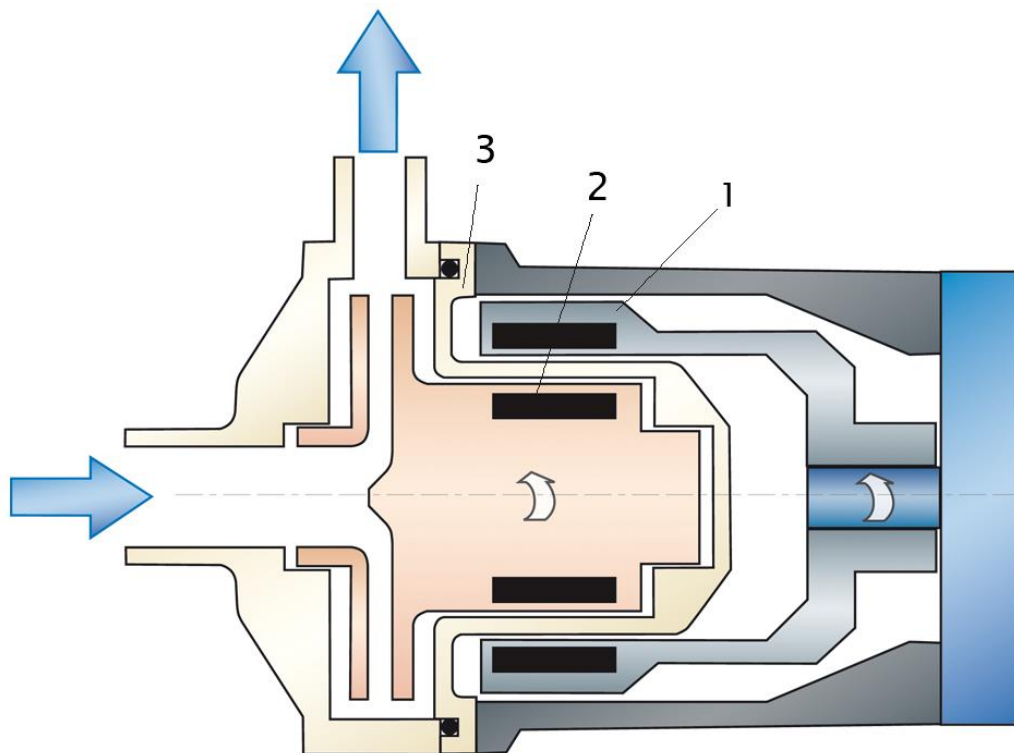

### 1.2. Receiving inspection

Although precaution is taken by us when packing and shipping, we urge you to carefully check the shipment on receipt. Make sure that all parts and accessories listed on the packing list are accounted for. Immediately report any damage or shortage to the transport company and to us.

### 1.3. Storage



If the equipment is to be stored prior to installation, place it in a clean location. Clean the pump thoroughly before installation.

When in storage, turn the shaft by hand at least twice per week.

# 1. INSTALLATION

---

## 1.4. Foundation



The pump-motor unit must stand on and be fixed to a sufficiently rigid structure that can support the entire perimeter on which the unit stands. The foundation on a firm bottom is the most satisfactory. Once the pump is in position, adjust level with metal shims between the feet and the surface on which it stands. Check that the feet of the pump-motor unit stand well on each of them. The surface on which the foundation stands must be flat and horizontal. If the unit is fitted on a steel structure, make sure that it is supported so that the feet do not warp. In any case, it is advisable to fit some anti-vibration rubber pieces between the pump and the brickwork.

For close-coupled type, pump motor alignment is not required.

## 1.5. Environment



- There should be enough space in the vicinity of the pump in order to operate, maintain and repair it.
- The area in which the pump is operated, must be sufficiently ventilated. Excessive temperature, humidity or dirt may affect the pump operation.
- Behind the cooling fan of the motor there must be sufficient room for the hot air to escape the motor.

## 1.6. Suction and discharge piping



A pump is generally part of a piping system that can include a number of components such as valves, fittings, filters, expansion joints, instruments, etc. The way the piping is arranged and the positioning of the components has a great influence on the operation and the lifetime of the pump. The pump cannot be used as a support for the components connected to it.

The flow of liquid from the pump must be as even as possible. It is advisable to avoid any tight bends or drastic reductions of diameters that may cause flow resistance in the installation. In case of diameter reduction, it is advisable to use appropriate conical reductions (possibly eccentric on suction side and concentric on discharge side) at changes of diameter and at a minimum distance from pump connections of five diameters.

### 1.6.1. Connection of discharge pipe



A shut-off / regulation valve is normally fitted on the discharge side. It cuts off the pump from the line and adjusts the output. Never adjust flow rate using the valve on the suction pipe.

### 1.6.2. Connection of suction pipe



The suction piping is very important for the correct operation of the pump assembly. It must be as short and as direct as possible. If a longer suction line is unavoidable, the diameter should be large enough, i.e. at least as the inlet connection on the pump, to ensure less flow resistance. In any case, suction must be carried out properly avoiding any air locks.



The CTM pumps are single-stage centrifugal type, thus non self-priming. It will therefore always be necessary to install a bottom valve in all cases when the static height of the liquid is lower than the suction height of the pump. The suction piping must be without air inlets that are more probable with long suction lines or if suction occurs with negative head. Critical points in these terms are also the seals between flanges and the seals of the valve stems. Even a bit of air let into the suction line can cause serious operating problems that can make the pump stop.



# 1. INSTALLATION

---

## 1.7. Health and safety

The pump must be installed according to local and national safety rules.



The pumps are constructed for particular applications. Do not use the pump on applications different from that for which it was sold without consulting us to ascertain its suitability.

### 1.7.1. Protection



In the interest of health and safety it is essential to wear protective clothing and safety goggles when operating, and/or working in the vicinity of Tapflo pumps.

### 1.7.2. Electrical safety



Do not carry out any maintenance or/and operation on the pump while it is running or before it has been disconnected from the power supply. Avoid any danger caused by electric power (for details see current regulations in force). Check that electrical specifications on the motor nameplate are equivalent to the power supply to which it will be connected.

### 1.7.3. Chemical hazard



Whenever the pump is to be used for pumping a different liquid, it is essential to clean the pump beforehand in order to avoid any possible reaction between the two products. Before pump disassembly clean it thoroughly.

### 1.7.4. Dry running



Do not start nor carry out running tests before filling the pump with liquid. Always avoid dry operation of the pump. Start the pump when it is completely filled and with the valve on the discharge side almost completely closed.

### 1.7.5. Noise level



CTM pumps, including the motor, in normal operating conditions produce a sound level below 80 dB(A). The major sources of noise are: liquid turbulence in the installation, cavitation or any other abnormal operation that is independent from the pump construction nor the pump manufacturer. The user must provide suitable protective means if the sources of noise could produce a harmful noise level for operators and for the environment (in compliance with current local regulations).

### 1.7.6. Temperature hazards



Raised temperature can cause damage on the pump and/or piping and may also be hazardous for personnel in the vicinity of the pump/piping. The hot or cold parts of the machine must be protected to avoid accidental contacts

### 1.7.7. Rotating parts



Do not tamper with the protection of the rotating parts, do not touch or approach rotating parts in movement.

### 1.7.8. Powerful magnetic field



Magnetically driven pumps use high intensity magnets. All pacemaker carriers must not approach magnetic components; intense magnetic field can disturb heart pace.

# 1. INSTALLATION

## 1.8. Example of installation

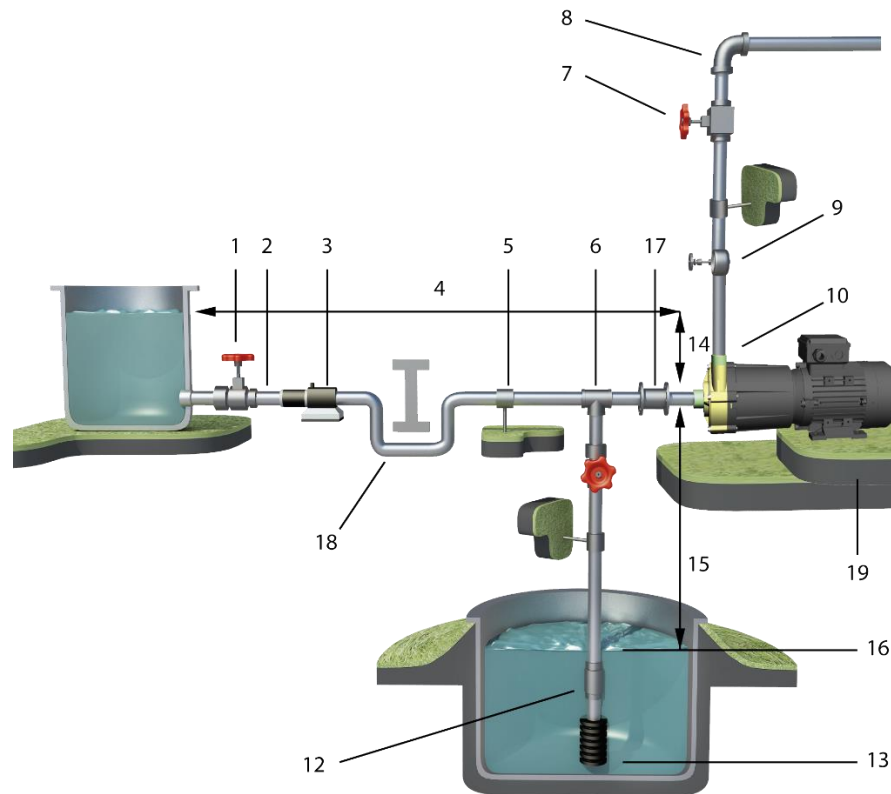

- 1) YES: Gate valve (may also be near pump in case of long piping)
- 2) With positive head: tilt of piping towards pump
- 3) YES: line strainer if particles are present
- 4) NO: air pockets – the circuit must be short and straight
- 5) YES: pipe fastening
- 6) Suction line as short and direct as possible
- 7) YES: adjusting gate valve on outlet
- 8) Bends placed after valves and instruments
- 9) YES: attachment for gauge or safety pressure switch
- 10) NO: elbow joints (and other parts) on the pump (discharge and suction lines)
- 11) YES: check valve (with negative suction lift)
- 12) YES: strainer if particles are present
- 13) Suction head varies according to flow in order to prevent windage
- 14) Suction head
- 15) Immersion depth
- 16) YES: expansion joint (necessary with long pipes or hot liquids) and/or anti-vibration facility during discharge and suction; anchored near to pump
- 17) YES: overcoming obstacles at lower depths
- 18) Fix the pump by the fixing holes provided: the supports must be level

## 1.9. Solids



It is not recommended to use liquid with suspended solids, especially if sensitive to magnetism. In case dirty liquids are to be pumped and this was not mentioned at the time of ordering, it is necessary to contact Tapflo technical service before activating the pump.

# 1. INSTALLATION

## 1.10. Instruments



In order to ensure a proper control of the performance and the conditions of the installed pump, we recommend using the following instruments:

- a pressure-vacuum gauge on the suction piping;
- a pressure gauge on the discharge piping.

The pressure intakes must be made of straight pieces of piping at a distance of minimum five diameters from the pump inlets. The pressure gauge on discharge must always be fitted between the pump and the shut-off / regulation valve. The output can be read on the pressure gauge, transformed into meters and then compared with the typical curves.

### 1.10.1. Electric power

The electric power absorbed by the motor can be measured by means of a wattmeter.

### 1.10.2. Optional instruments

The optional instruments can indicate if pump is working in an abnormal way. The abnormal conditions can be caused by: accidentally closed valves, lack of pumped liquid, overloads, etc.

### 1.10.3. Thermometer

If the temperature of the pumped liquid is a critical parameter, provide the installation with a thermometer (preferably on the suction side).

## 1.11. Motor connection



An expert electrician must always carry out the electrical connection. Compare the power supply with the data plate specifications and then choose a suitable connection. The type of connection is stated on the motor data plate and can be Y (star) or D (Delta), according to the power supply of the motor (see table below).

STAR	DELTA



Follow the connection standard used in the plant. In no case connect the electrical motor directly to supply network but use a suitable electric switchboard equipped with a knife switch and suitable safety devices (e.g. motor breaker switches) in the power circuit. Safety devices against overloads must also protect the motors. Make sure that the motor has suitable grounding and that it has been connected properly.

## 2. OPERATION

---

### 2. OPERATION

#### 2.1. Start-up

- Check manually that the motor is free to turn by moving the motor cooling fan.
- Make sure that the piping is not clogged and is free from residues or foreign objects. Make sure that the liquid flows regularly into the pump.
- The pump and piping connected to it, at least the suction pipe, must be full of liquid. Any air or gas must be carefully released. In case of suction with negative head, fill the suction piping and check how the bottom valve works. It must guarantee that the liquid must not flow back, emptying therefore the suction pipe and eventually disconnection of the pump.
- The suction shut-off valve (if any) must be completely open.
- The shut-off / regulation valve on the discharge side must be completely closed.



- The motor must turn in the same direction as the arrow shown on the pump. The direction of rotation is always clockwise looking at the pump from the motor side; check by starting briefly, then looking at the direction of rotation of the motor fan through the fan lid. If it is wrong, the motor must be stopped immediately. Change the connection to the terminals of the electric motor (chapter 1.11 "Motor connection") and repeat the procedure described above.



- Any auxiliary connections must all be connected.

##### 2.1.1. Starting the pump



Start the electric motor and open the discharge adjustment/shutoff valve gradually until the desired output has been reached. The pump must not turn more than two or three minutes with discharge closed. A longer operation in these conditions can damage the pump seriously.

If the pressure shown on the pressure gauge on the discharge piping does not increase, turn off the pump immediately and release pressure carefully. Repeat the connection procedure.



If there are changes of flow rate, head, density, temperature or viscosity of the liquid, stop the pump and get in touch with our technical service.

##### 2.1.2. Restarting after power shut-off

In case of accidental stopping, make sure that the non-return valve has prevented backflow and check that the motor cooling fan has stopped. Start the pump again following the instructions of chapter 2.1.1 "Starting the pump".

#### 2.2. Stopping the pump



It is advisable to close the discharge shut-off / regulation valve gradually and stop the motor immediately after. The reverse sequence is not recommended, especially with larger pumps or longer delivery piping. That is to avoid any problems due to water hammering. If a suction shutoff valve has been installed, it is advisable to close it completely.

# 3. MAINTENANCE

## 3. MAINTENANCE



Maintenance work on electrical installations must be performed by qualified personnel and only when the power supply has been shutoff. Follow the local and national safety regulations.

### 3.1. Inspections

The CTM range pumps have been designed and tested to run for 5000 hours in ideal working conditions. Please note that it is a conservative figure since the actual duty point of your pump can substantially modify this value. Additional factors such as intermittent operation, type of pumped liquid and installation in the plant may affect the life of components that are subject to wear. In any case, Tapflo advises to service pumps every year, even when used in ideal operating conditions.

- Periodically check suction and discharge pressures.
- Inspect the motor according to the instructions from the motor manufacturer.

### 3.2. Location of faults

Leakage from the pump	Insufficient flow rate or pressure in pump	No pressure on the discharge	Irregular discharge flow /	Noise and vibrations	The pump gets clogged	Overheating of the pump	Abnormal wear	Bushings life too short	Possible reason	Solution
X	X	X							Wrong direction of rotation	Invert the direction of rotation
	X	X	X	X					Insufficient suction head (NPSH)	Increase available NPSH: ➤ Raise the suction reservoir ➤ Lower the pump ➤ Reduce the vapour pressure ➤ Increase the diameter of the suction pipe ➤ Make suction pipe short and direct
		X							Pump is clogged	Clean the pump
X	X		X	X			X		Cavitation	Increase suction pressure
	X		X	X			X		The pump sucks air	Make sure all connections are tight
		X	X	X					Suction pipe is blocked	Check pipes / valves and filters on the suction line
	X			X					Discharge pressure too high	Reduce the head by increasing pipe diameter and/or reduce number of valves and bends
				X		X			Flow rate too high	Reduce the flow: ➤ Partially close the discharge valve ➤ Reduce the impeller diameter (contact us) ➤ Reduce the rotation speed
X	X			X	X	X	X		Liquid temperature too high	Cool the liquid
X								X	Pump runs dry	Always fill pump before start-up
								X	Wrong material of bushings for the liquid	Mount bushings in other material (contact us)
				X			X		Loads on the pipes	Connect the pipes independent of the pump
				X	X	X	X		Foreign objects in the liquid	Use a filter on the suction side
		X							Shut-off valve closed on suction side	Check and open the valve
	X								Discharge pressure too low	Increase the pressure – install an impeller with a bigger diameter (contact us)
					X	X			Pump is not filled with liquid	Fill pump with liquid
	X			X					Liquid parameters different than calculated	Check pumped liquid parameters
	X			X					Magnetic coupling damaged or insufficient	Check and replace magnet assemblies
				X					Rotating unit out of balance	Check and replace magnet assemblies
				X		X			Inner bushes worn or damaged	Check bushing and replace if necessary

# 3. MAINTENANCE

## 3.3. Disassembly of the pump



The disassembly should only be performed by qualified personnel.



Each operation carried out on the machine must always be carried out once all the electrical contacts have been disconnected. The pump-motor unit must be placed in a position where it cannot be started unintentionally.



Before servicing in any way the parts that come in contact with the pumped liquid, make sure that the pump has been fully emptied and washed. When draining the liquid, make sure that there is no danger for people or the environment.



The static and rotating bushings are usually made from very fragile sintered material and therefore have to be handled with extreme care.

The numbers put in brackets, refer to the part numbers in the spare part drawings and spare part lists in chapter 4 "Spare parts".

### 3.3.1. Disassembly procedure



**Fig. 3.3.1**

Unscrew the casing mounting screws [141] and take off the pump casing [13].



**Fig. 3.3.2**

Pull out the front static bushing [1521] along with the O-ring [1821].



**Fig 3.3.3**

Pull out the impeller / magnet assembly [90] from the isolation shell [12].



**NOTE!** Take extra care while proceeding with this point. The magnetic field generated by the magnets can cause finger seizure between the impeller and the impeller [90] and isolation shell [11].

### 3. MAINTENANCE

---



**Fig 3.3.4**

Using a sharp tool take off the front rotating bushing [1511].

**NOTE!** Level the bushing equally on each side.



**Fig 3.3.5**

Using a sharp tool take off the rear rotating bushing [1512].

**NOTE!** Level the bushing equally on each side.



**Fig 3.3.6**

**CTM20** – Remove the O-ring [1812] from the impeller / magnet assembly.

**CTM25/32** – Remove the O-rings [1811, 1812] from the impeller / magnet assembly.

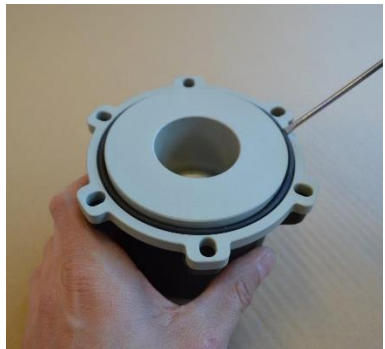

**Fig 3.3.7**

Remove the casing O-ring [18] from the isolation shell [12].

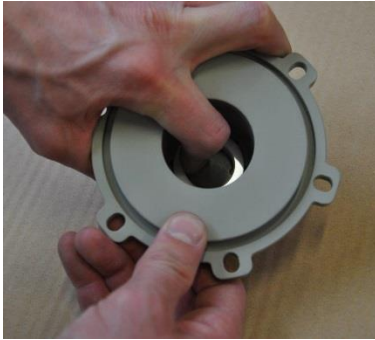

**Fig 3.3.8**

Take out the isolation shell [12] from the lantern [11].

### 3. MAINTENANCE

---



**Fig 3.3.9**

Pull out the rear static bushing [1522] along with the O-ring [1822].



**Fig 3.3.10**

Loosen the lock screws (2 x [161] on CTM20/25; 1 x [1611] and 2 x [1612] on CTM32).



**Fig 3.3.11**

Take out the external magnet assembly [16] form the lantern [11].



**Fig 3.3.12**

Unscrew the motor mounting screws [111] and remove the lantern [11] form the motor.



The pump is now completely disassembled. Check all components, especially the O-rings and bushings, for wear or damage and replace if necessary.

The components that can affect the correct operation of the pump if not regularly replaced, are:

**CTM 20-7**

- Casing O-ring (18)
- Rotating bushes (1511) + (1512)
- Static bushes (1521) + (1522)
- O-rings (1821) + (1812) + (1822)



# 3. MAINTENANCE

---

## CTM 25-8, 25-10 and 32-12,5

- Casing O-ring (18)
- Rotating bushes (1511) + (1512)
- Static bushes (1521) + (1522)
- O-rings (1811) + (1821) + (1812) + (1822)

For spare part kits see chapter 4.3 Recommended spare parts.

## 3.4. Assembly of the pump

The assembly procedure is done in the reverse order to the disassembly.

Nevertheless there are a few things that you have to remember in order to assemble the pump correctly.



**Fig. 3.4.1**

Wet the O-rings with alcohol before assembly to make the procedure easier.

### 3.4.1. Test run



We recommend you to conduct a test run of the pump before installing it in the system, so no liquid gets wasted if the pump leaks or perhaps does not start accordingly to wrong assembly of the pump.

After a few weeks of operation retighten the screws with appropriate torque.

# 4. SPARE PARTS

## 4. SPARE PARTS

### 4.1. Spare parts drawing

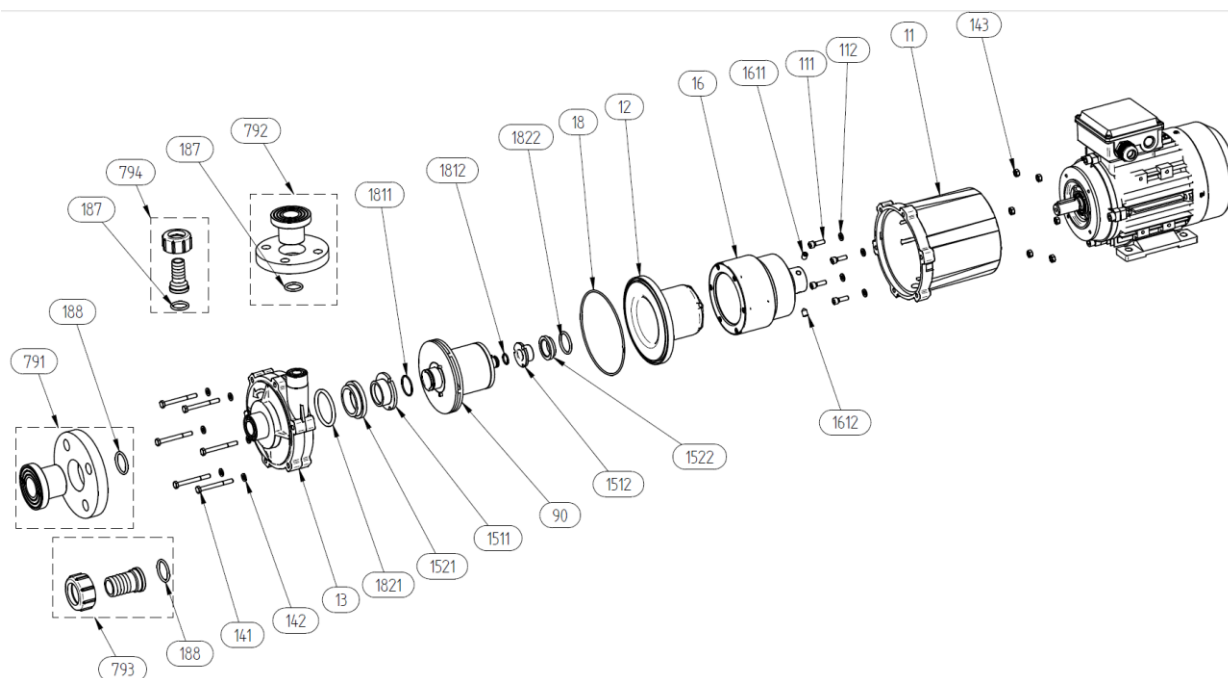

### 4.2. Spare parts list

Pos.	Description	Pump model				Material
		20-7	25-8	25-10	32-12,5	
11	Lantern	1	1	1	1	PP-GF (30%)
111	Motor mounting screw	4	4	4	4	A4-70
112	Motor mounting washer	-	-	-	4	A4-70
12	Isolation shell (rear casing)	1	1	1	1	PP-GF (30%), PVDF
13	Pump casing	1	1	1	1	PP-GF (30%), PVDF
141	Casing mounting screw	6	6	6	6	A4-70
142	Casing mounting washer	6	6	6	6	A4-70
143	Casing mounting nut	6	6	6	6	A4-70
1511	Front rotating bushing	1	1	1	1	PTFE – graphite, SiC
1512	Rear rotating bushing	1	1	1	1	PTFE – graphite, SiC
1521	Front static bushing	1	1	1	1	Al <sub>2</sub> O <sub>3</sub> (ceramic), SiC
1522	Rear static bushing	1	1	1	1	Al <sub>2</sub> O <sub>3</sub> (ceramic), SiC
16	External magnet assembly	1	1	1	1	Cast iron / NdFeB
161	Lock screw	2	2	2	-	St 45H
1611	Lock screw	-	-	-	1	St 45H
1612	Lock screw	-	-	-	2	St 45H
18	Casing O-ring	1	1	1	1	EPDM, FKM
1811	O-ring	-	1	1	1	EPDM, FKM
1812	O-ring	1	1	1	1	EPDM, FKM
1821	O-ring	1	1	1	1	EPDM, FKM
1822	O-ring	1	1	1	1	EPDM, FKM
90	Impeller	1	1	1	1	PP / NdFeB, PVDF / NdFeB
<b>OPTIONS</b>						
187	O-ring	2*	2*	2*	1	EPDM, FKM
188	O-ring	-	-	-	1	EPDM, FKM
791	Flange connection on inlet	2*	2*	2*	1	PP, PVDF
792	Flange connection on outlet	-	-	-	1	PP, PVDF
793	Hose connection on inlet	2*	2*	2*	1	PP, PVDF
794	Hose connection on outlet	-	-	-	1	PP, PVDF

\* CTM20/25 has the same size of inlet/outlet

## 4. SPARE PARTS

### 4.3. Recommended spare parts

Depending on the nature of the liquid and temperature etc., some parts of the pump are subject to wear and have to be replaced. We recommend having the following parts in stock:

- O-ring KIT (xx-y – pump size, e.g. 25-10; z – material, E for EPDM, V for FKM):

CTMxx-y zOR KIT		
Pos.	Description	Q-ty
18	Casing O-ring	1
1811	O-ring	1
1812	O-ring	1
1821	O-ring	1
1822	O-ring	1

- WETEND (xx-y – pump size, e.g. 25-10; z – material, P for PP, K for PVDF):

WETEND-CTMxx-yz		
Pos.	Description	Q-ty
12	Isolation shell (rear casing)	1
13	Pump casing	1
141	Casing mounting screw	6
142	Casing mounting washer	6
143	Casing mounting nut	6
1511	Front rotating bushing	1
1512	Rear rotating bushing	1
1521	Front static bushing	1
1522	Rear static bushing	1
18	Casing O-ring	1
1811	O-ring	1
1812	O-ring	1
1821	O-ring	1
1822	O-ring	1
90	Impeller	1

### 4.4. How to order parts

When ordering spare parts for Tapflo pumps, please let us know what is the **model number** and **serial number** from the pump's name plate. Then just indicate the part numbers from the spare parts list and quantity of each item.

# 5. DATA

## 5. DATA

### 5.1. Pump code

The model number on the pump and on the front page of this instruction manual tells the pump size and materials of the pump.

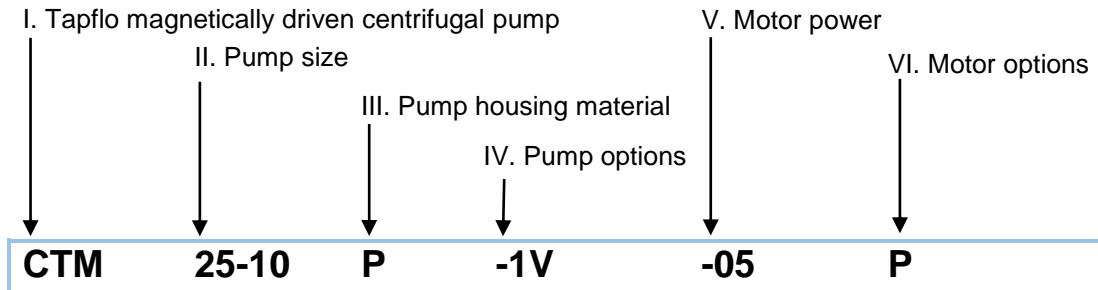

**I. CTM = Tapflo magnetically driven centrifugal pump**

**II. Pump size:**

20-7  
25-8  
25-10  
32-12.5

**III. Pump housing material:**

P = PP (Polypropylene)  
K = PVDF (Polyvinylidene fluoride)

**IV. Pump options:**

**1. Casing O-ring:**

blank\* = EPDM for PP, FKM for PVDF pump  
F = FEP / Silicone  
V = FKM

**2. Static bushing:**

blank\* = Al<sub>2</sub>O<sub>3</sub> (ceramic)  
S = SiC (silicone carbide)

**3. Rotating bushing:**

blank\* = PTFE-graphite  
S = SiC (silicone carbide)

**4. Connection options:**

blank\* = BSP external thread  
F = Flange DIN PN10 (CTM20, CTM25);  
PN16 (CTM32)  
H = Hose connection

**V. Motor power / IEC mechanical size:**

01 = 0.12 kW / 56  
02 = 0.25 kW / 63  
05 = 0.55 kW / 71  
07 = 0.75 kW / 80  
11 = 1.1 kW / 80

**VI. Motor options**

P = 1-phase motor (220/230 VAC)  
V = 500 V motor  
T = PTC motor protection  
F60 = 60 Hz motor

\* = standard execution

# 5. DATA

## 5.2. Dimensions

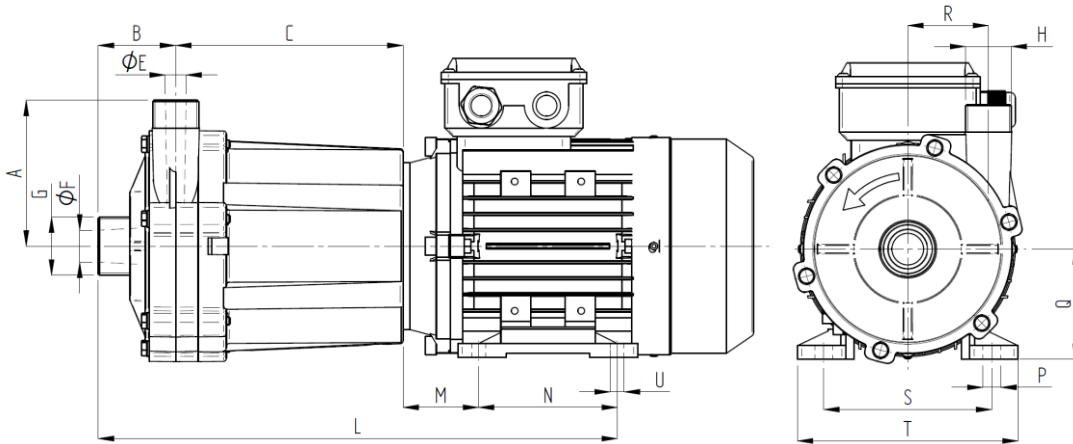

Dimensions in mm (where other is not indicated)

Dimensions in inch (where other is not indicated)

General dimensions only, ask us for detailed drawings. Changes reserved without notice.

MODEL	CTM 20-7	CTM 25-8	CTM 25-10	CTM 32-12.5
A	70	90	100	105
	2.76	3.54	3.94	4.13
B	48	58.50	63	56
	1.89	2.30	2.48	2.20
C	93.5	100.5	136.5	164
	3.68	3.96	5.37	6.46
ØE	15	18	18	15
	0.59	0.71	0.71	0.59
ØF	15	18	18	23
	0.59	0.71	0.71	0.91
G	¾"	1"	1"	1 ¼"
	¾	1	1	1 ¼
H	¾"	1"	1"	1"
	¾	1	1	1
L	248.5	279	334.5	374.5
	9.78	10.98	13.17	14.74
M	36	40	45	54.5
	1.42	1.57	1.77	2.15
N*	71	80	80	100
	2.80	3.15	3.15	3.94
P*	9	10	10	13
	0.22	0.28	0.28	0.51
Q	56	63	71	80
	2.20	2.48	2.80	3.15
R	35	39.5	43.5	58.5
	1.38	1.56	1.71	2.30
S*	90	100	112	125
	3.54	3.94	4.41	4.92
T	112	126	141	160
	4.41	4.96	5.55	6.3
U*	5,5	7	7	10
	0.22	0.28	0.28	0.39
<b>MOTOR</b>				
<b>POWER</b>	0.12 kW	0.25 kW	0.55, 0.75 kW	0.75, 1.1 kW
<b>SIZE</b>	56	63	71	80
<b>OPTIONAL CONNECTIONS</b>				
<b>FLANGE</b>	-	DN25	DN25	DN32 / DN25
<b>HOSE</b>	-	Ø20	Ø 20	Ø32 / Ø20

\*The dimension may vary depending on motor brand



## 5. DATA

### 5.3. Materials, data and limits

<b>Casing and isolation shell</b>	PP-GF (30%) or PVDF
<b>Impeller</b>	PP or PVDF
<b>Lantern (not wetted)</b>	PP-GF (30%)
<b>Static bushings</b>	Ceramic (standard) or SiC
<b>Rotating bushings</b>	PTFE-graphite (standard) or SiC
<b>O-rings</b>	FKM, EPDM, FFKM, FEP/Silicone
<b>Magnets</b>	NdFeB
<b>Motor</b>	IEC standard, 3x380 VAC (other on request), 2900 rpm, IP55, B34 frame
<b>Pressure rating</b>	<b>CTM20:</b> PP pumps: PN4 at 20°C, PN2 at 70°C PVDF pumps: PN4 at 20°C, PN2 at 80°C <b>CTM25 and CTM32:</b> PP pumps: PN6 at 20°C; PN2 at 70°C PVDF pumps: PN6 at 20°C; PN2 at 90°C
<b>Temperature</b>	PP pumps: 0°C - 70°C PVDF pumps: 0°C - 80°C (CTM20); 0°C - 90°C (CTM25, CTM32)
<b>Kinematic viscosity</b>	200 cSt (max)
<b>Dynamic viscosity</b>	10 cP (max)

### 5.4. Mounting torques and dimensions of screws/nuts

The following tightening torques are recommended :

Screw / nut type	Description	Pump model			
		CTM 20-7	CTM 25-8	CTM 25-10	CTM 32-12,5
	<b>Pos. 141 hexagonal screw</b> Mounting torque [Nm] Thread	6 M5	9 M6	9 M6	9 M6
	<b>Pos. 143 hexagonal nut</b> Mounting torque [Nm] Thread	6 M5	9 M6	9 M6	9 M6
	<b>Pos. 111 allen screw</b> Mounting torque [Nm] Thread	6 M5	6 M5	9 M6	9 M6

# 5. DATA

## 5.5. Performance curves

The performance curves are based on water at 20°C. Speed 2900 rpm.

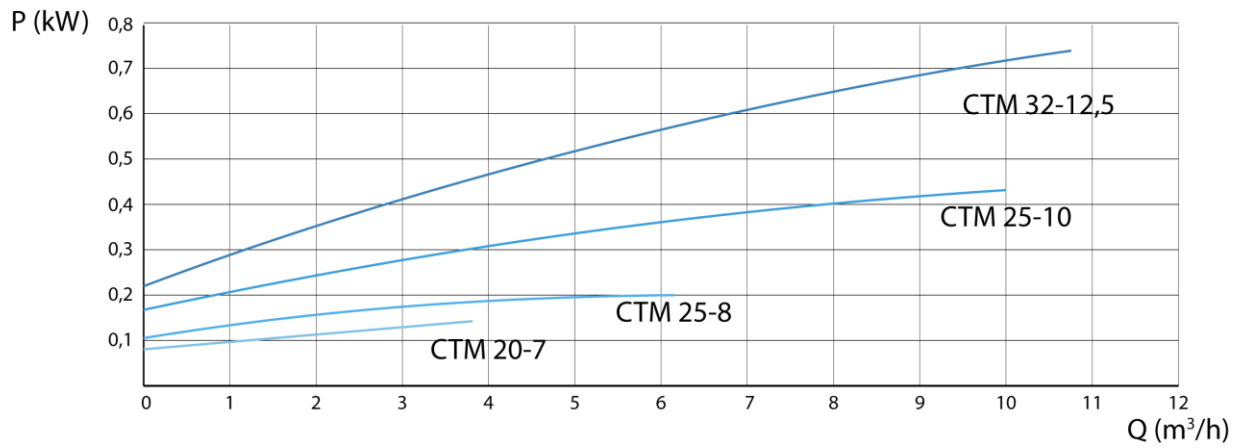
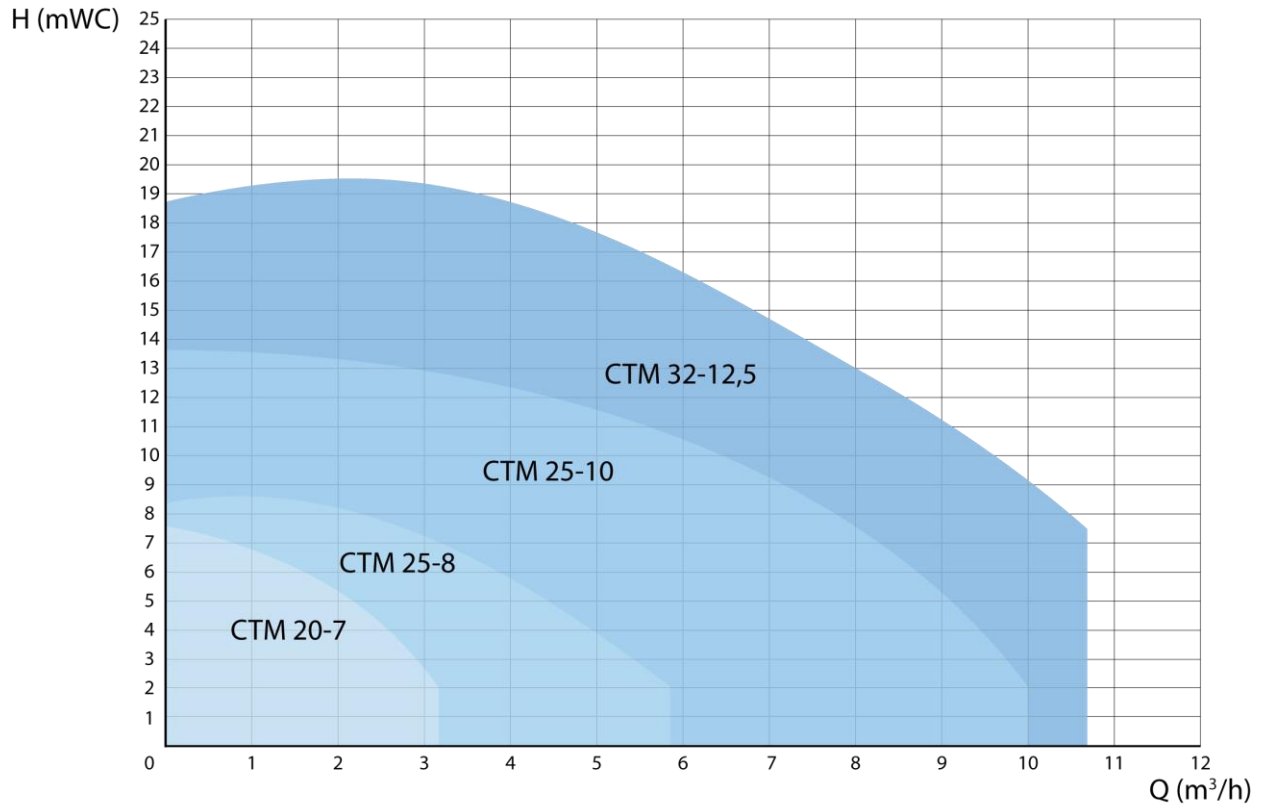

# 5. DATA

## 5.6. Permitted loads on inlet and outlet

We recommend not to exceed the following loads and forces reacting on the inlet and outlet.

CTM 20		
Direction	Load [N] (inlet/outlet)	Moment of force (inlet/outlet) [Nm]
X	15	3
Y	20	4
Z	15	3

CTM 25		
Direction	Load [N] (inlet/outlet)	Moment of force (inlet/outlet) [Nm]
X	15	3
Y	20	4
Z	15	3

CTM 32		
Direction	Load [N] (inlet/outlet)	Moment of force (inlet/outlet) [Nm]
X	15	3
Y	20	4
Z	15	3

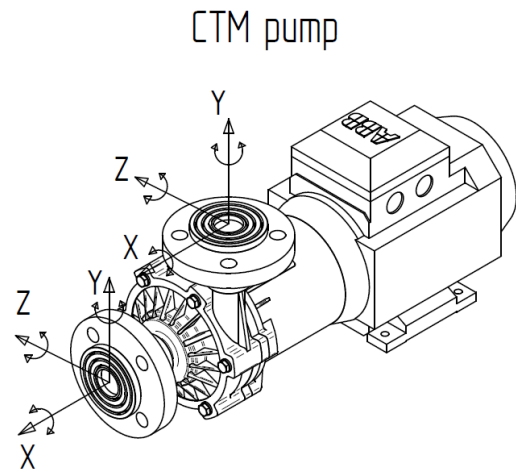



## 6. WARRANTY

---

### 6. WARRANTY

#### 6.1. Returning parts

When returning parts to Tapflo please follow this procedure:

- Consult Tapflo for shipping instructions.
- Cleanse or neutralize and rinse the part/pump. Make sure the part/pump is completely empty from liquid.
- Pack the return articles carefully to prevent any damage during transportation.

***Goods will not be accepted unless the above procedure has been complied with.***

#### 6.2. Warranty

Tapflo warrants products under conditions as stated below for a period of not more than 12 months from installation and not more than 24 months from date of manufacturing.

1. The following terms and conditions apply to the sale of machinery, components and related services and products, of Tapflo (hereinafter “the products”).
2. Tapflo (the manufacturer) warrants that:
  - a. its products are free of defects in material, design and workmanship at the time of original purchase;
  - b. its products will function in accordance with Tapflo operative manuals; Tapflo does not guarantee that the product will meet the precise needs of the Customer, except for those purposes set out in any invitation to render documents or other documents specifically made available to Tapflo before entering into this agreement;
  - c. high quality materials are used in the construction of the pumps and that machining and assembly are carried out to the highest standards.

Except as expressly stated above, Tapflo makes no warranties, express or implied, concerning the products, including all warranties of fitness for a particular purpose.

3. This warranty shall not be applicable in circumstances other than defects in material, design, and workmanship. In particular warranty shall not cover the following:
  - a. Periodic checks, maintenance, repair and replacement of parts due to normal wear and tear (seals, O-rings, rubber items, bushings, etc.);
  - b. Damage to the product resulting from:
    - b.1. Tampering with, abuse or misuse, including but not limited to failure to use the product for its normal purposes as stated at the time of purchase or in accordance with Tapflo instructions for use and maintenance of the product, or the installation or improper ventilation or use of the product in a manner inconsistent with the technical or safety standard in force;
    - b.2. Repairs performed by non-skilled personnel or use of non-original Tapflo parts;
    - b.3. Accidents or any cause beyond the control of Tapflo, including but not limited to lightning, water, fire, earthquake, and public disturbances, etc.;

## 6. WARRANTY

---

4. The warrantee shall cover the replacement or repairing of any parts, which is documented faulty due to construction or assembling, with new or repaired parts free of charges delivered by Tapflo. Parts subjected to normal tear and wear shall not be covered by the warranty. Tapflo shall decide as to whether the defective or faulty part shall be replaced or repaired.
5. The warrantee of the products shall be valid for a period in accordance to the current law from the date of delivery, under the condition that notice of the alleged defect to the products or parts thereof be given to Tapflo in written within the mandatory term of 8 days from the discovery. Repair or replacement under the terms of this warranty shall not give a right to an extension to, or a new commencement of, the period of warranty.
6. Repair or replacement under the terms of this warranty may be fulfilled with functionally equivalent reconditioned units. Tapflo qualified personnel shall be solely entitled to carry out repair or replacement of faulty parts after careful examination of the pump. Replaced faulty parts or components will become the property of Tapflo.
7. The products are built in accordance with standard CE normative and are tested (where applicable) by Tapflo. Approval and tests by other control authority are for the customer's account. The products shall not be considered defective in materials, design or workmanship if they need to be adapted, changed or adjusted to conform to national or local technical or safety standards in force in any country other than that for which the unit was originally designed and manufactured. This warranty shall not reimburse such adaptations, changes or adjustments, or attempt to do so, whether properly performed or not, nor any damage resulting from them, nor any adaptation, change or adjustments to upgrade the products from their normal purpose as described in the products operative manual without the prior written consent of Tapflo.
8. Installation, including electric and other connections to utility mains according to Tapflo drawings, is for the cost and responsibility of the customer, unless otherwise agreed in writing.
9. Tapflo will not be liable on any claim, whether in contract, tort, or otherwise, for any indirect, special, incidental, or consequential damages, caused to the customer or to third parties, including loss of profits, arising by any possible infringement of par. 3 above or by the customer or third parties being in the impossibility of using the products.

Steady the above, Tapflo liability to the customer or third parties from any claim, whether in contract, tort, or otherwise, shall be limited to the total amount paid by the customer for the product that caused the damages.

# 6. WARRANTY

## 6.3. Warranty form

Company: _____	
Telephone: _____	Fax: _____
Address: _____	
Country: _____	Contact Name: _____
E-mail: _____	
Delivery Date: _____	Date of pump installation: _____
Pump type: _____	
Serial No (see name plate): _____	
Description of the fault: _____	
_____	
_____	
<b>The installation:</b>	
Liquid: _____	
Temperature [°C]: _____	Viscosity [cPs]: _____ Spec grav. [kg/m <sup>3</sup> ]: _____ pH-value: _____
Content of particles: _____	%, of max size [mm]: _____
Flow [l/min]: _____	Duty [h/day]: _____ No of starts per day: _____
Discharge head [mWC]: _____	Suction head / lift [m]: _____
Other: _____	
_____	
<b>Place for sketch of installation:</b>	

# TAPFLO AB

## Sweden

Filaregatan 4 | S-442 34 Kungälv

Tel: +46 303 63390

Fax: +46 303 19916

E-mail addresses:

Commercial questions: [sales@tapflo.com](mailto:sales@tapflo.com)

Orders: [order@tapflo.com](mailto:order@tapflo.com)

Tech support: [support@tapflo.com](mailto:support@tapflo.com)

## Tapflo products and services are available in 56 countries on 6 continents.

Tapflo is represented worldwide by own Tapflo Group Companies and carefully selected distributor's assuring highest Tapflo service quality for our customers' convenience.

AUSTRALIA | BELARUS | BELGIUM | BOSNIA | BRAZIL | BULGARIA | CHILE | CHINA | COLOMBIA | CROATIA | CZECH/SLOVAKIA | DENMARK | ECUADOR | ESTONIA | FINLAND | FRANCE | GREECE | GERMANY | HONG-KONG | HUNGARY | INDIA | INDONESIA | IRAN | IRELAND | ISRAEL | ITALY | JAPAN | KAZAKHSTAN | LATVIA | LITHUANIA | MACEDONIA | MALAYSIA | MEXICO | MONTENEGRO | THE NETHERLANDS | NEW ZEALAND | NORWAY | POLAND | PORTUGAL | PHILIPPINES | ROMANIA | RUSSIA | SINGAPORE | SLOVENIA | SOUTH AFRICA | SOUTH KOREA | SPAIN | SWEDEN | SWITZERLAND | SYRIA | TAIWAN | THAILAND | UKRAINE | UNITED ARAB EMIRATES | UNITED KINGDOM | USA | VIETNAM

## Tapflo Group Companies

### Austria

Tapflo Austria  
Tel: +43 732 27292910  
[sales@tapflo.at](mailto:sales@tapflo.at)

### Azerbaijan

Tapflo Azerbaijan LLC  
Tel: +994 502660799  
[sales@tapflo.az](mailto:sales@tapflo.az)

### Baltic States

Tapflo Latvia  
Tel: +371 67472205  
[riga@tapflo.lv](mailto:riga@tapflo.lv)

### Belarus

Tapflo Belarus  
Tel: +375 17 3934609  
[sales@tapflo.by](mailto:sales@tapflo.by)

### Bulgaria

Tapflo EOOD  
Tel: +359 (2) 974 18 54  
[sofia@tapflo.org](mailto:sofia@tapflo.org)

### Croatia

Tapflo GmbH  
Tel: +385 91 4884 666  
[sales@tapflo.hr](mailto:sales@tapflo.hr)

### Czech Republic

Tapflo s.r.o.  
Tel: +420 513033924  
[tapflo@tapflo.cz](mailto:tapflo@tapflo.cz)

### China

Tapflo (Wuxi)  
Tel: +86 510 8241 7602  
[sales@tapflo.cn](mailto:sales@tapflo.cn)

### Denmark

Tapflo Danmark  
Tel: +45 36 454600  
[info@tapflo.dk](mailto:info@tapflo.dk)

### France

Tapflo France  
Tel: +33 1 34 78 82 40  
[info@tapflo.fr](mailto:info@tapflo.fr)

### Georgia

Tapflo Georgia  
Tel: +995 577 463010  
[sales@tapflo.ge](mailto:sales@tapflo.ge)

### India

Tapflo Fluid Handling India Pvt Ltd  
Tel: +91 20 65000215  
[ad@tapflo.in](mailto:ad@tapflo.in)

### Ireland

Tapflo Ireland Ltd  
Tel: +353 1 2011911  
[info@tapflo.ie](mailto:info@tapflo.ie)

### Italy

Tapflo Italia  
Tel: +39 0362307698  
[info@tapfloitalia.com](mailto:info@tapfloitalia.com)

### Japan

Tapflo Japan K.K.  
Tel: +81-3-6240-3510  
[tapflojp@tapflo.co.jp](mailto:tapflojp@tapflo.co.jp)

### Kazakhstan

Tapflo Kazakstan  
Tel: +7 727 3278347  
[sales@tapflo.kz](mailto:sales@tapflo.kz)

### Poland

Tapflo Sp. z o.o.  
Tel: +48 58 5304200  
[export@tapflo.pl](mailto:export@tapflo.pl)

### Romania

S.C. Tapflo Rom. S.r.l.  
Tel: +40 21 3451255  
[sales@tapflo.ro](mailto:sales@tapflo.ro)

### Russia

Tapflo Company  
Tel: +7 495 232 18 28  
[sales@tapflo.com.ru](mailto:sales@tapflo.com.ru)

### Serbia

Tapflo d.o.o.  
Tel: +381 21 44 58 08  
[sales@tapflo.rs](mailto:sales@tapflo.rs)

### Slovakia

Tapflo s.r.o.  
Tel: +421 911 137 883  
[tapflo@tapflo.sk](mailto:tapflo@tapflo.sk)

### Slovenia

Tapflo GmbH  
Tel: +386 68 613 474  
[ales@tapflo.hr](mailto:ales@tapflo.hr)

### Spain

Tapflo Iberica  
Tel: +34 91 8093182  
[avives@tapfloiberica.es](mailto:avives@tapfloiberica.es)

### South Africa

Tapflo (Pty) Ltd  
Tel: +27 31 701 5255  
[sales@tapflo.co.za](mailto:sales@tapflo.co.za)

### Turkey

Tapflo Makina Ltd  
Tel: +90 216 467 33 11  
[sales@tapflo.com.tr](mailto:sales@tapflo.com.tr)

### Ukraine

TOB Tapflo  
Tel: +380 44 222 68 44  
[sales@tapflo.com.ua](mailto:sales@tapflo.com.ua)

### Uzbekistan

Tapflo Uzbekistan  
Tel.: +998 712340940  
[sales@tapflo.uz](mailto:sales@tapflo.uz)

### United Kingdom

Tapflo (UK) Ltd  
Tel: +44 2380 252325  
[sales@tapflo pumps.co.uk](mailto:sales@tapflo pumps.co.uk)