

tapflo®

CTM MAGNETIC DRIVE CENTRIFUGAL PUMPS

edition 2015 rev 1

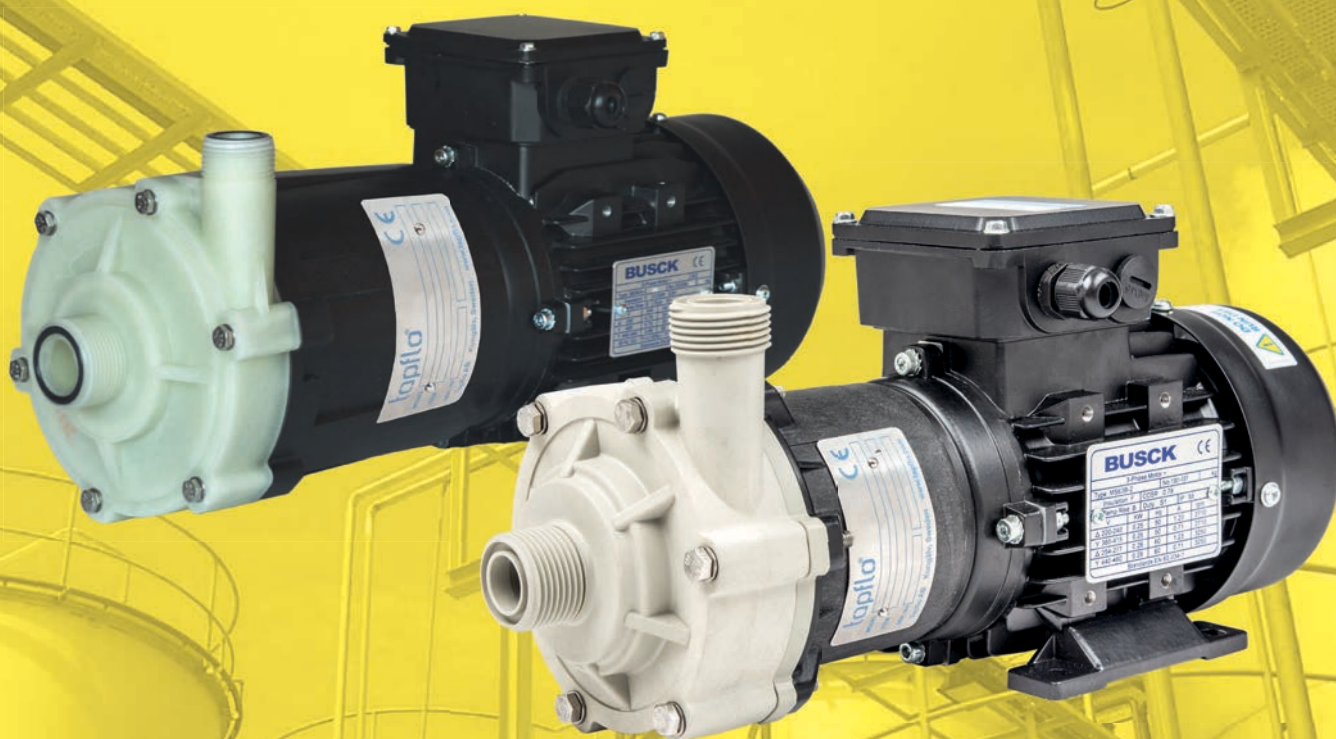

» All about your flow

www.tapflo.com

All about your flow. Everywhere.

Tapflo is a leading pump manufacturer with the ambition to provide a wide range of premium products for various industrial applications. Tapflo is represented by own companies and independent distributors in more than 60 countries spread over the world on 6 continents – products and spare parts are available worldwide. The headquarters are situated in Sweden.



About Tapflo

Tapflo Group is an independent, Swedish, family owned, manufacturer and global supplier of Air operated diaphragm pumps, centrifugal pumps and other industrial process equipment.

The company was founded as Temag Pumpar in Kungälv, Sweden in 1980 and has since then been working with design and manufacture of thermoplastic, metal and sanitary series diaphragm pumps and also with complete range of centrifugal pumps and industrial equipment. After years of dynamic development the company evolved into Tapflo Group with worldwide operations.

Quality certified

At Tapflo we believe that quality is one of the highest values, both for our customers as well as our employees. As a result, we comply with various globally recognised certification and quality control institutions. Many of our products comply with EC ATEX directives for equipment intended for use in explosion hazardous environments.

The aseptic series is EHEDG certified (European Hygienic Engineering & Design Group), the pharmaceutical series has USP VI approval.

All our products are obviously CE marked and followed by our comprehensive instruction manuals. Tapflo manufacturing process is certified according to ISO 9001:2001.



Our values

■ Long term engagement is our core

Our aim is to continuously provide premium products according to evolving needs of our customers. That is why we see each customer relationship as a long term commitment.

■ Local means on your terms

Tapflo is your global partner providing local support. No matter where your plant is located you can expect us to support you locally.

■ Flexibility the foundation of good service

We are prepared to deal with reality, knowing that in practice this means answering questions, offering solutions and supplying spare parts with a minimal loss of time.

■ Customizing to bring the product to the needs

Our intention is always to help our clients find the most cost effective solutions to increase their company's efficiency. If this means changing the design of the pump we see it as a challenge - not a problem.

■ To produce is to develop

When you are actively involved in the manufacturing of a product, it is almost impossible not to discover ways to improve it. This allows us to frequently offer solutions that are even more sustainable and efficient.

CTM Magnetic Drive Pumps

ideal for safe fluid handling

Tapflo CTM horizontal centrifugal pumps are pumps of centrifugal type where the power from the motor is transmitted to the centrifugal impeller by means of a magnetic coupling.

CTM pumps are designed and manufactured for chemical transfer and circulation surface treatment industries.

CTM is a perfect choice for a chemically corrosive and toxic liquids.

■ Features & Benefits

- ✓ **No leakage**
safe working environment
and environmental friendly
- ✓ **Economical operation**
high degree of efficiency
and no waste of product
- ✓ **Magnetic power transmission**
no mechanical seal problems
- ✓ **Safe handling of hazardous fluids**
seal less pump
- ✓ **Hermetic system**
no poisonous or dangerous vapours

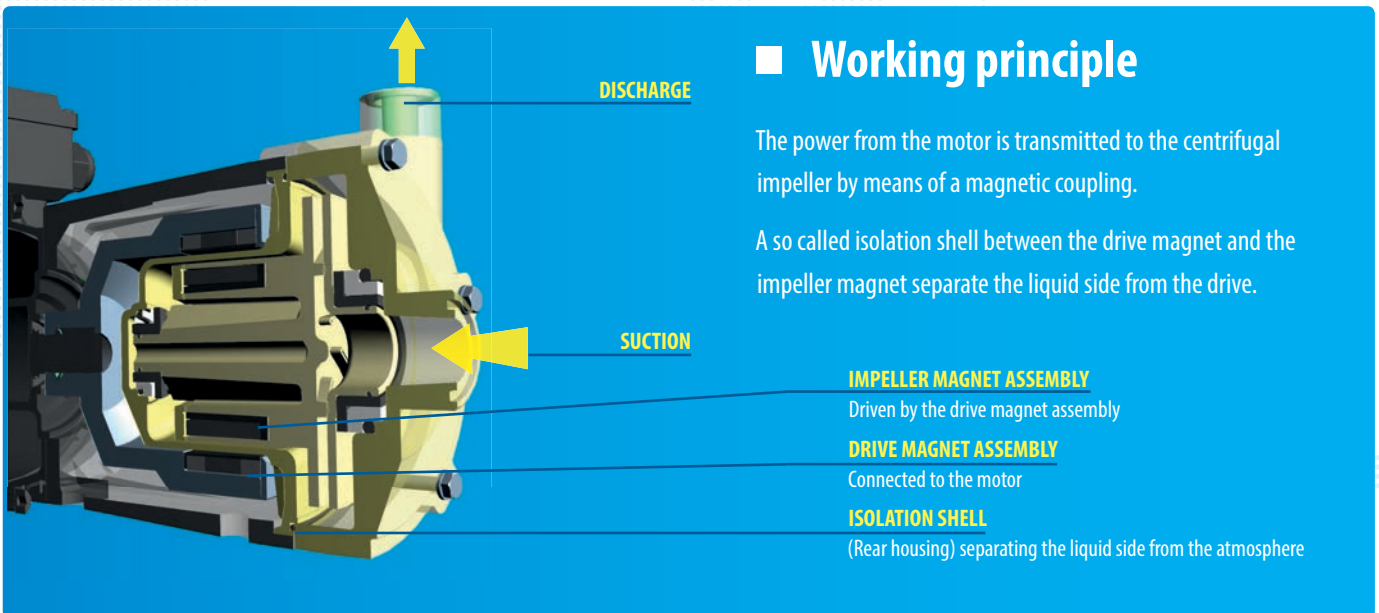

Perfect pump
for clean and thin liquids like pure
chemicals, acids and alkalis.

Wide range of applications

CTM pumps are used in most industries where liquids are pumped. The pumps handle many types of low and normal viscous clean liquids such as chemical aggressive and toxic.

Transfer of chemicals

Transfer of various chemicals from storage tanks to smaller containers

Surface treatment

Transfer, filtering and circulation of surface treatment baths

Food and beverage

Pumping of CIP detergent used for cleaning of pipes and other food process equipment

Water treatment

Dosing of acids and alkalis used as cleaning chemicals in nanofiltration

Chemical manufacture

Pumping of chemicals in industrial detergent equipment

Demineralization

Demi-water circulation and transfer in many industrial applications

Photo processing

Transfer of photo development chemicals and inclusion in processing machines

Liquid crystal manufacture

Pumping of concentrated acids and alkalis



Compact but powerful

CTM is a close coupled compact pump ideal for service in little spaces like in OEM installations.

Reliable design without shaft

The impeller magnet assembly is designed with very powerful bushings where a conventional crack sensitive shaft is not needed. This results in a pump that has fewer parts and is very reliable in service.

Powerful magnet couplings

Our magnets in NdFeB (Neodymium-iron-boron) with our unique magnet cage system have a superior strength also under demanding circumstances. The power from the drive is transmitted even at high temperatures and with high specific gravity liquids. Furthermore the robust steel frame for the external magnet increases the magnet power and grants a gentle startup of the pump.

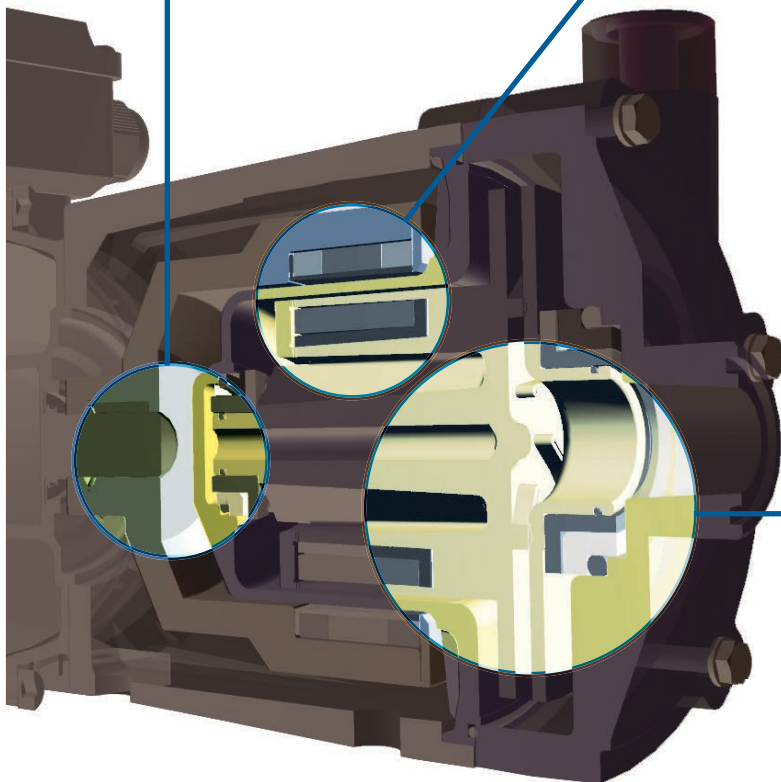

Non-metallic pumps

The wetted components are non-metallic injection moulded thermoplastics enabling excellent corrosion resistance. The version in PP-GF (glass fibre reinforced polypropylene) provides great mechanical strength and allows liquid temperatures up to 70°C. The PVDF (PolyVinylidene DiFluoride) version has superior chemical resistance and allows temperatures up to 80°C.

Excellent performance with magnet cage system

The magnets are totally encapsulated in their cage with the unique system that avoids the use of resins and glue. This grants a safe system with better performance at high temperatures. Furthermore the impeller is injection moulded, resulting in excellent performance and no weak points. CTM 20-7 has a semi-open impeller while models CTM 25-8, CTM 25-10 and CTM 32-12,5 have closed impellers to obtain best pumping parameters.

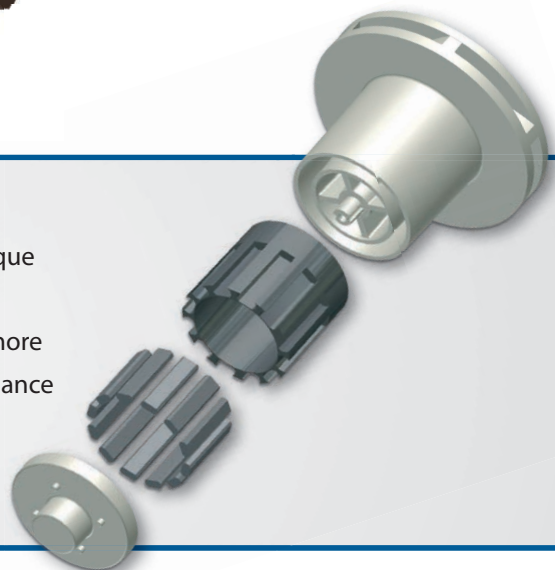

Performance curves

Performance curves are based on 2900 rpm motor speed.
Please contact us for individual detailed performance curves.

H = Head in mWC
Q = Flow in m³/h
N = Required motor power in kW

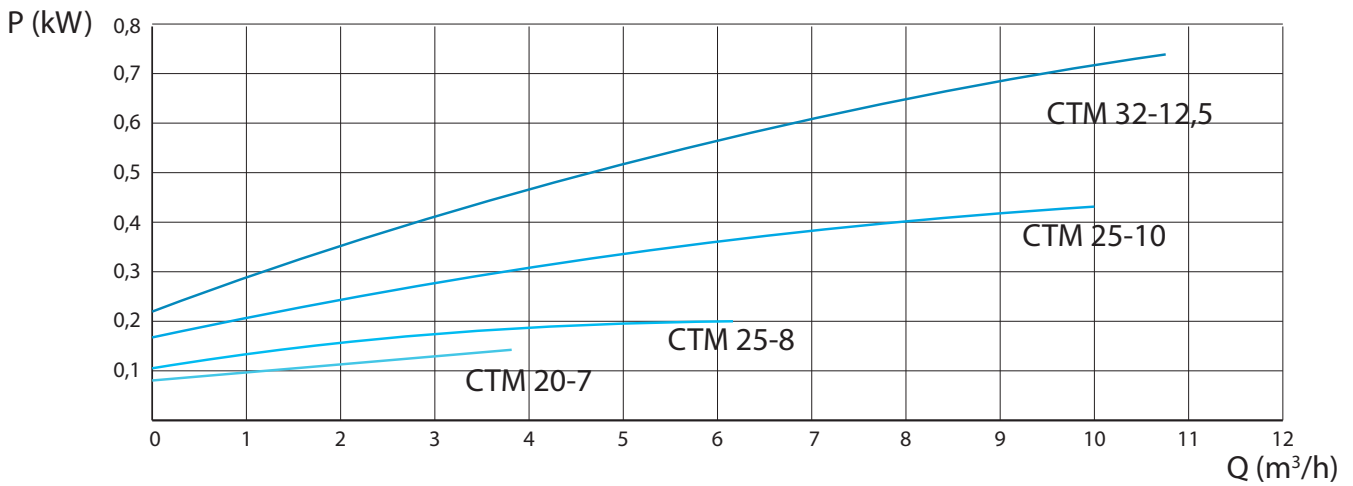
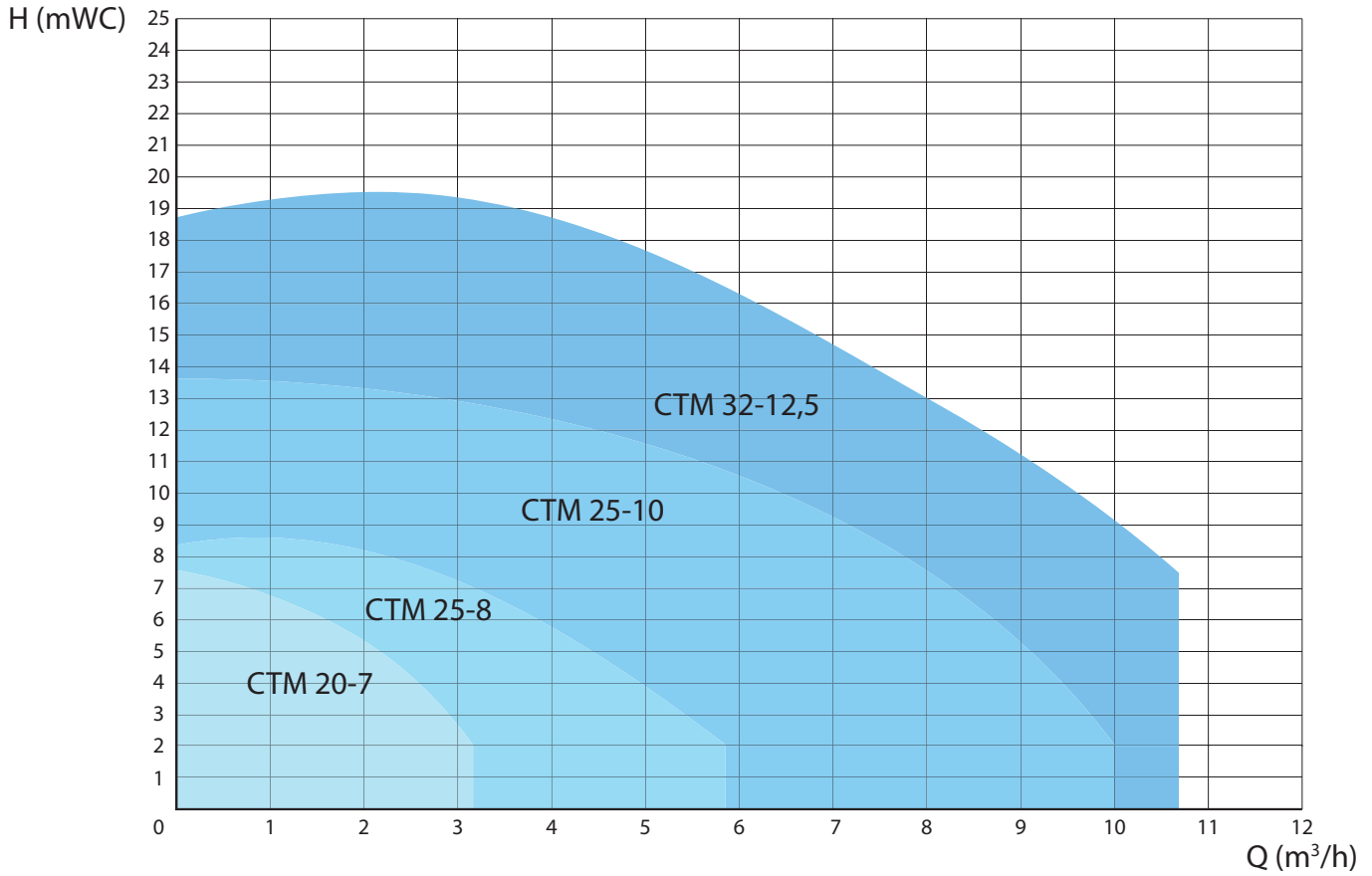

Changes reserved without notice



NEW CTM 32-12,5
Currently the all new, more powerful
CTM pump is being introduced

Technical data

Dimensions

	CTM 20-7	CTM 25-8	CTM 25-10	CTM 32-12.5 <small>NEW</small>
A	70	90	100	105
	2.76	3.54	3.94	4.13
B	48	58.50	63	56
	1.89	2.30	2.48	2.20
C	93.5	100.5	136.5	164
	3.68	3.96	5.37	6.46
ØE	15	18	18	15
	0.59	0.71	0.71	0.59
ØF	15	18	18	23
	0.59	0.71	0.71	0.91
G	¾"	1"	1"	1 ¼"
	¾	1	1	1 ¼
H	¾"	1"	1"	1"
	¾	1	1	1
L	248.5	279	334.5	374.5
	9.78	10.98	13.17	14.74
M	36	40	45	54.5
	1.42	1.57	1.77	2.15
N*	71	80	80	100
	2.80	3.15	3.15	3.94
P*	9	10	10	13
	0.22	0.28	0.28	0.51
Q	56	63	71	80
	2.20	2.48	2.80	3.15
R	35	39.5	43.5	58.5
	1.38	1.56	1.71	2.30
S*	90	100	112	125
	3.54	3.94	4.41	4.92
T	112	126	141	160
	4.41	4.96	5.55	6.3
U*	5.5	7	7	10
	0.22	0.28	0.28	0.39
MOTOR				
POWER	0.12 kW	0.25 kW	0.55, 0.75 kW	0.75, 1.1 kW
SIZE	56	63	71	80
OPTIONAL CONNECTIONS				
FLANGE	-	DN25	DN25	DN32 / DN25
HOSE	-	Ø20	Ø 20	Ø32 / Ø20

Dimensions in mm (where other is not indicated) | Dimensions in inch (where other is not indicated)

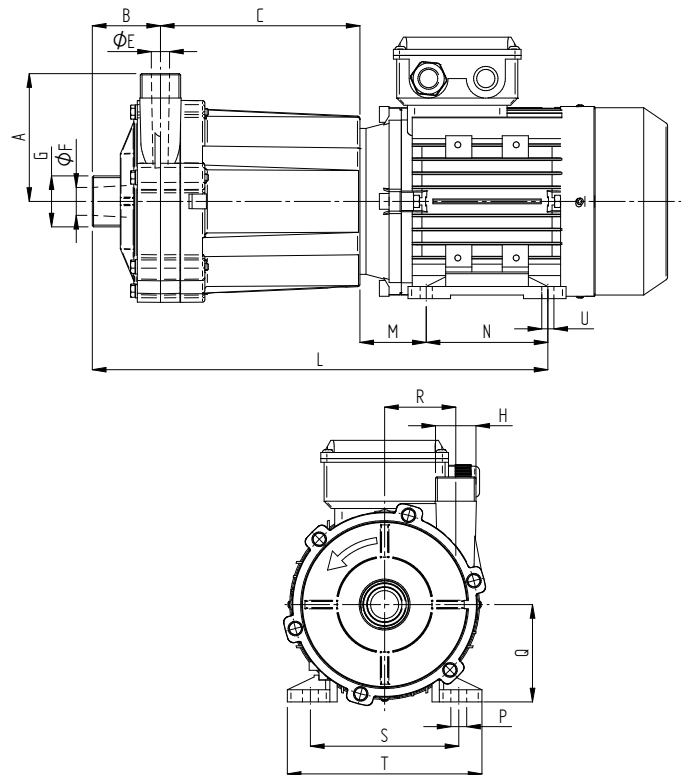

General characteristics

Temperature range	PP pumps: 0°C - 70°C PVDF pumps: 0°C - 80°C (CTM20); 0°C - 90°C (CTM25, CTM32)
System pressure rating	CTM20: PP pumps: PN4 at 20°C, PN2 at 70°C PVDF pumps: PN4 at 20°C, PN2 at 80°C CTM25 and CTM32: PP pumps: PN6 at 20°C, PN2 at 70°C PVDF pumps: PN6 at 20°C, PN2 at 90°C
Viscosity	200 cSt max
Motor	IEC standard, 3x380 VAC (other voltage upon request), 2900 rpm, IP55, frame B3/B14

CTM Pump code

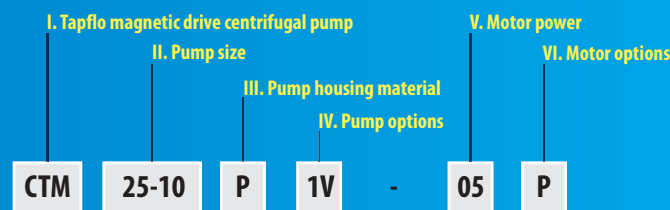

I. CTM = Tapflo magnetic drive centrifugal pump

II. Pump size: 20-7 | 25-8 | 25-10 | 32-12.5

III. Pump housing material:

P = PP (Polypropylene)

K = PVDF (Polyvinylidene fluoride)

IV. Pump options:

1. Casing O-ring:

blank* = EPDM for PP, FKM for PVDF pump

F = FEP / Silicone

V = FKM

2. Static bushing:

blank* = Al2O3 (ceramic)

S = SiC (silicone carbide)

3. Rotating bushing:

blank* = PTFE-graphite

S = SiC (silicone carbide)

4. Connection options:

blank* = BSP external thread

F = Flange DIN PN10 (CTM20, CTM25); PN16 (CTM32)

H = Hose connection

* = standard execution

V. Motor power / IEC mechanical size:

01 = 0.12 kW / 56

02 = 0.25 kW / 63

05 = 0.55 kW / 71

07 = 0.75 kW / 80

11 = 1.1 kW / 80

VI. Motor options

P = 1-phase motor (220/230 VAC)

V = 500 V motor

T = PTC motor protection

F60 = 60 Hz motor



Ask us for complete pump code with all available options and executions. Changes reserved without notice.

TAPFLO AB

Sweden

Filaregatan 4 | S-442 34 Kungälv

Tel: +46 303 63390

Fax: +46 303 19916

E-mail addresses:

Commercial questions: sales@tapflo.com

Orders: order@tapflo.com

Tech support: support@tapflo.com

Tapflo products and services are available in 64 countries on 6 continents.

Tapflo is represented worldwide by own Tapflo Group Companies and carefully selected distributors assuring highest Tapflo service quality for our customers' convenience.

AUSTRALIA | AUSTRIA | AZERBAIJAN | BELARUS | BELGIUM | BOSNIA | BRAZIL | BULGARIA | CHILE | CHINA | COLOMBIA | CROATIA | CZECH REPUBLIC | DENMARK | ECUADOR | ESTONIA | FINLAND | FRANCE | GREECE | GEORGIA | GERMANY | HONG-KONG | HUNGARY | INDIA | INDONESIA | IRAN | IRELAND | ISRAEL | ITALY | JAPAN | KAZAKHSTAN | LATVIA | LITHUANIA | MACEDONIA | MALAYSIA | MEXICO | MONTENEGRO | THE NETHERLANDS | NEW ZEALAND | NORWAY | POLAND | PORTUGAL | PHILIPPINES | ROMANIA | RUSSIA | SERBIA | SINGAPORE | SLOVAKIA | SLOVENIA | SOUTH AFRICA | SOUTH KOREA | SPAIN | SWEDEN | SWITZERLAND | SYRIA | TAIWAN | THAILAND | TURKEY | UKRAINE | UNITED ARAB EMIRATES | UNITED KINGDOM | USA | UZBEKISTAN | VIETNAM

Tapflo Group Companies

Austria

Tapflo Austria
Tel: +43 732 27292910
sales@tapflo.at

Azerbaijan

Tapflo Azerbaijan LLC
Tel: +994 502660799
sales@tapflo.az

Baltic States

Tapflo Latvia
Tel: +371 67472205
riga@tapflo.lv

Belarus

Tapflo Belarus
Tel: +375 17 3934609
sales@tapflo.by

Bulgaria

Tapflo EOOD
Tel: +359 (0)2 974 18 54
sofia@tapflo.org

Croatia

Tapflo GmbH
Tel: +385 91 4884 666
sales@tapflo.hr

Czech Republic

Tapflo s.r.o.
Tel: +420 513 033 924
tapflo@tapflo.cz

China

Tapflo (Wuxi)
Tel: +86 510 8241 7602
sales@tapflo.cn

Denmark

Tapflo Danmark
Tel: +45 36 454600
info@tapflo.dk

France

Tapflo France
Tel: +33 1 34 78 82 40
info@tapflo.fr

Georgia

Tapflo Georgia
Tel: +995 577 463010
sales@tapflo.ge

India

Tapflo Fluid Handling India Pvt Ltd
Tel: +91 20 65000215
ad@tapflo.in

Ireland

Tapflo Ireland Ltd
Tel: +353 1 2011911
info@tapflo.ie

Italy

Tapflo Italia
Tel: +39 0362307698
info@tapfloitalia.com

Japan

Tapflo Japan K.K.
Tel: +81-3-6240-3510
tapflojp@tapflo.co.jp

Kazakhstan

Tapflo Kazakstan
Tel: +7 727 3278347
sales@tapflo.kz

Poland

Tapflo Sp. z o.o.
Tel: +48 58 530 42 00
export@tapflo.pl

Romania

S.C. Tapflo Rom. S.r.l.
Tel: +40 21 3451255
sales@tapflo.ro

Russia

Tapflo Company
Tel: +7 495 232 18 28
sales@tapflo.com.ru

Serbia

Tapflo d.o.o.
Tel: +381 21 44 58 08
sales@tapflo.rs

Slovakia

Tapflo s.r.o.
Tel: +421 911 137 883
tapflo@tapflo.sk

Slovenia

Tapflo GmbH
Tel: +386 68 613 474
sales@tapflo.hr

Spain

Tapflo Iberica
Tel: +34 91 8093182
avives@tapfloiberica.es

South Africa

Tapflo (Pty) Ltd
Tel: +27 31 701 5255
sales@tapflo.co.za

Turkey

Tapflo Makina Ltd
Tel: +90 216 467 33 11
sales@tapflo.com.tr

Ukraine

TOB Tapflo
Tel: +380 44 222 68 44
sales@tapflo.com.ua

Uzbekistan

Tapflo Uzbekistan
Tel: +998 712370940
sales@tapflo.uz

United Kingdom

Tapflo (UK) Ltd
Tel: +44 2380 252325
sales@tapflo pumps.co.uk

www.tapflo.com